

AFC-600

Atomflo™ Controller

The Atomflo™ 600 controller is the brains of the argon plasma system. It is equipped with a 600 W radio frequency (RF) power supply, auto-tuning matching network, three mass flow controllers for the argon and two process gases (oxygen, nitrogen, or hydrogen), a computer with Windows 10 operating system, and an eight-inch touch screen. LabVIEW software provides the user with a powerful interface to select recipes, choose control modes, and monitor the process conditions.

Controller features include:

- Real-time control of the RF power, argon and process gas flow rates, and plasma source temperature.
- Auto-tuning of the forward and reflected power using phase and magnitude detection.
- Unlimited storage of process recipes.
- Graph showing process parameters in real time.
- Warnings and alarms for out-of-spec process.
- Remote control and data logging via Ethernet.

For more information, contact Surfx at:

sales@surfxtechnologies.com or +1 310 558 0770.



AF-600 Specifications

Dimensions (W * D * H)

440 x 640 x 230 mm

17.3 x 25.1 x 9.1 inches

RF power

Maximum 600 W

At 27.12 MHz

Patented plasma technology

Atmospheric argon plasma

O₂, H₂, N₂ reactive gas chemistry

RF capacitive discharge

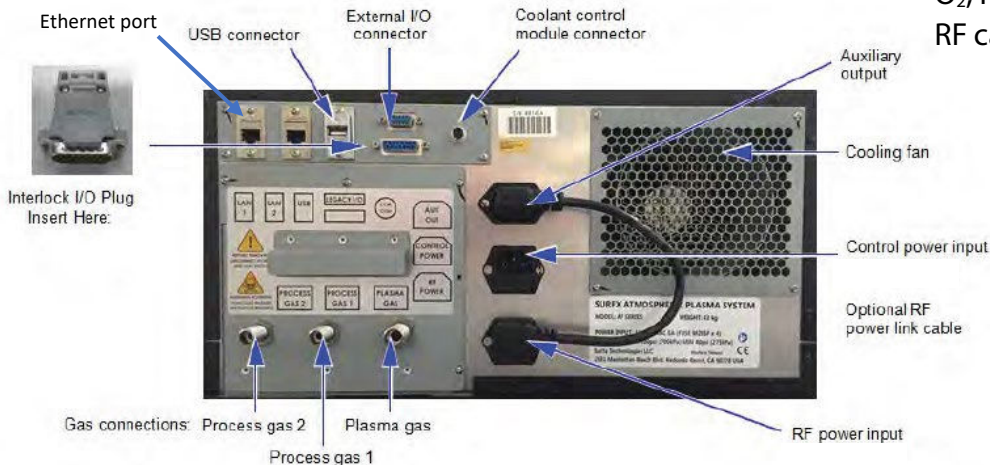

www.surfxtechnologies.com

North America

Surfx Technologies, LLC
Los Angeles, CA, USA
Ph: +1 (310) 558-0770
sales@surfxtechnologies.com

Asia

Surfx Technologies Taiwan Co. Ltd.
Taichung City, Taiwan
Ph: +886 4 2263 8200
salesasia@surfxtechnologies.com

AFC-600

The Atomflo™ 600 controller is designed to give our customers total control over the atmospheric pressure plasma with complete process traceability.

Gas Facilities

Plasma gases* (choose one)				
Type	Inlet Fitting**	Regulator	Max Flow (LPM)	Operating Pressure
Argon (Ar)	3/8-inch OD	CGA 580	40	0.35-0.7 MPa (50-100 psig)
Helium (He)	3/8-inch OD	CGA 580	60	0.35-0.7 MPa (50-100 psig)
Process gases* (choose two)				
Type	Inlet Fitting**	Regulator	Max Flow (LPM)	Supply Gas Pressure
Oxygen (O ₂)	1/4-inch OD	CGA 540	0.60	0.35-0.7 MPa (50-100 psig)
Nitrogen (N ₂)	1/4-inch OD	CGA 580	0.60	0.35-0.7 MPa (50-100 psig)
5.0% H ₂ in argon	1/4-inch OD	CGA 580	10.0	0.35-0.7 MPa (50-100 psig)

*Gas purity should be at least 99.99% (industrial grade).

**Swagelok bulkhead connector.

Facilities

Specifications	
Power supply	200 – 240 VAC, 8 A, 50/60 Hz
Air supply (CDA)	None
Dimensions (W*D*H)	437 x 650 x 232 mm (17.2 x 25.6 x 9.1 inches)
Weight	29 kg (64 lbs)

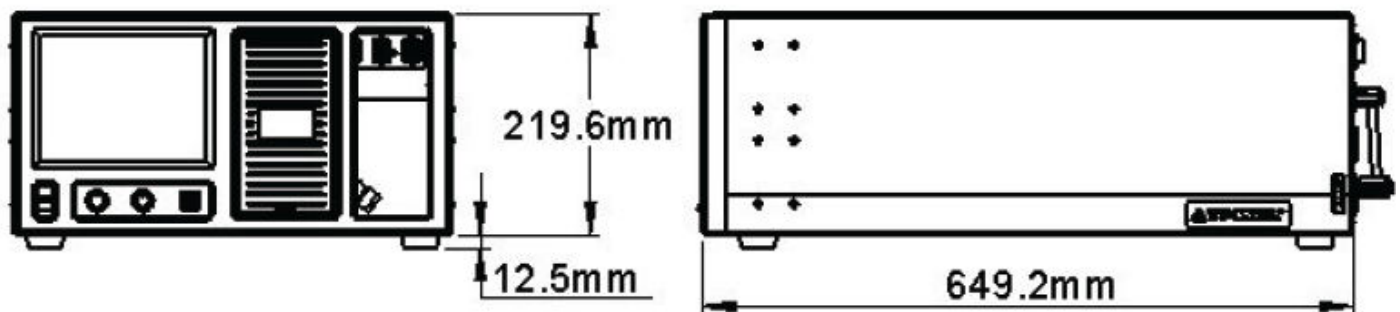

www.surfxtechnologies.com

North America
 Surfx Technologies, LLC
 Los Angeles, CA, USA
 Ph: +1 (310) 558-0770
sales@surfxtechnologies.com

Asia
 Surfx Technologies Taiwan Co. Ltd.
 Taichung City, Taiwan
 Ph: +886 4 2263 8200
salesasia@surfxtechnologies.com