

# STL-10

## 4-Lane Substrate Plasma Machine

The STL-10 is purpose built for plasma preparation of substrate before die bonding, wire bonding or molding. Intuitive software allows the programming of separate substrate sizes on any of the processing lanes. Whether you need extremely high-volume throughput or high mix capabilities, the STL-10 is perfectly suited for your lead frame plasma processing.

Inside the STL-10, a 4-lane conveyor applies the most advanced atmospheric plasma to your substrates. Surfx's Atomflo™ controller operates with low voltage, radio frequency (RF) power, and generates a uniform, particle free, and electrically neutral plasma that is safe on the most sensitive electronics.

The STL-10 has many options for single piece flow manufacturing with full traceability:

- Oxygen plasma for organic clean
- Cleanroom class 1,000
- 4 lane operation and high UPH

For more information, contact Surfx at:  
[mlee@surfxtechnologies.com](mailto:mlee@surfxtechnologies.com) or +886 965 567 200.

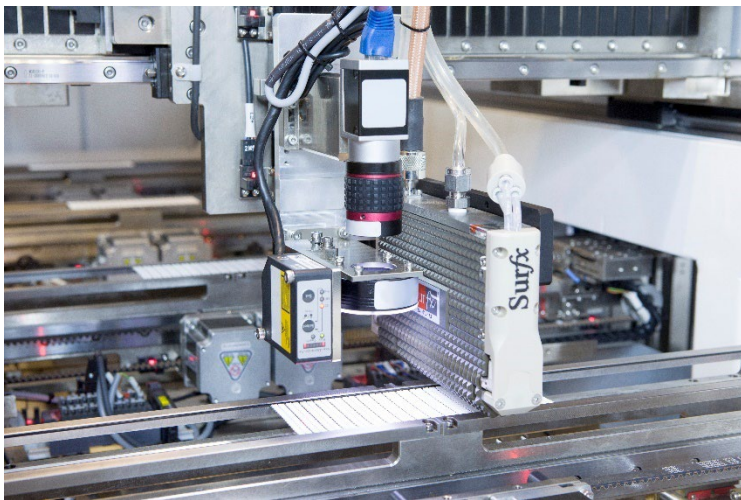

## STL-10 Specifications

### Substrate Size Range (mm)

- Length: 50 – 300 mm
- Width: 25 – 100 mm
- Thickness 0.1 – 10 mm

### Footprint (W \* D \* H)

1,650 x 2,100 x 1,750 mm

### Patented plasma technology

Atmospheric argon plasma  
O<sub>2</sub>, H<sub>2</sub>, N<sub>2</sub> plasma chemistry  
RF capacitive discharge

[www.surfxtechnologies.com](http://www.surfxtechnologies.com)

### North America

Surfx Technologies, LLC  
Los Angeles, CA, USA  
Ph: +1 (310) 558-0770  
[sales@surfxtechnologies.com](mailto:sales@surfxtechnologies.com)

### Asia

Surfx Technologies Taiwan Co. Ltd.  
Taichung City, Taiwan  
Ph: +886 4 2263 8200  
[salesasia@surfxtechnologies.com](mailto:salesasia@surfxtechnologies.com)

# STL-10

The STL-10 is designed specifically for precision plasma cleaning of semiconductors and electronics with zero damage, high reliability and high UPH.

Specifications	
Power supply	200~240 VAC, 50 - 60 Hz, 30 Amp full load
Normal power consumption	3 kW
Air supply (CDA)	60 - 90 psi (0.4 – 0.6 MPa) < 20 LPM
Footprint (W*D*H)	1,650 x 2,100 x 1,750 mm
Weight	2,500 kg
Exhaust (flange, factory flow required)	300 CFM (application dependent)
Motion system	
Work area of plasma ( W*D )	300 – 1,320 mm
X Y Z repeatability	XY: +/- 0.005 mm @ 3 sigma, Z: +/- 0.005 mm @ 3 sigma
Max speed	1,000 mm/s (X, Y)
Acceleration	1.0 g
Drive system	Linear Motor
Machine specifications	
Conveyor type	High speed gripper
Handling type	Magazine load and unload continuous
Throughput	1,350 UPH
Atomflo™ plasma specifications	
RF Power	600 W at 27.12 MHz
Main plasma gas	Argon (Ar)
Process gases	Oxygen (O <sub>2</sub> ), nitrogen (N <sub>2</sub> ), or hydrogen (5.0% H <sub>2</sub> in Ar)
Process specifications	
Nominal contact angle after plasma	WCA < 10° (native oxide on silicon wafer)
Plasma cleaning process	O <sub>2</sub> + Ar to remove organics, or H <sub>2</sub> + Ar to remove metal oxidation

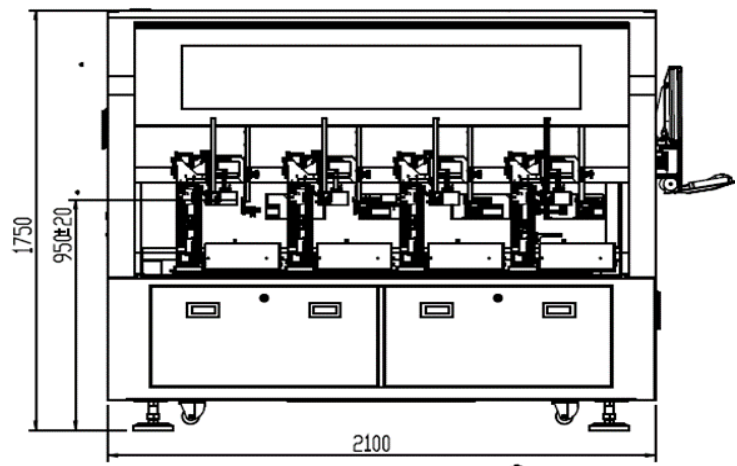
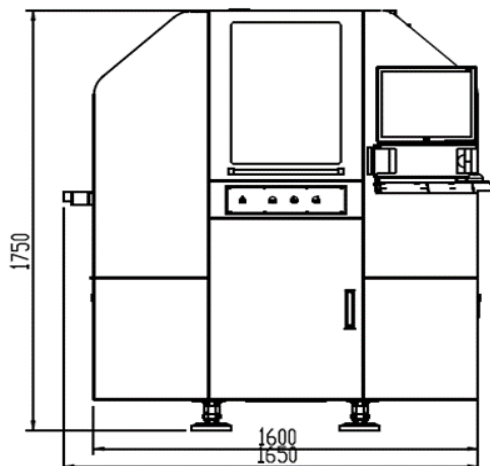

[www.surfxtechnologies.com](http://www.surfxtechnologies.com)

## North America

Surfx Technologies, LLC  
 Los Angeles, CA, USA  
 Ph: +1 (310) 558-0770  
[sales@surfxtechnologies.com](mailto:sales@surfxtechnologies.com)

## Asia

Surfx Technologies Taiwan Co. Ltd.  
 Taichung City, Taiwan  
 Ph: +886 4 2263 8200  
[salesasia@surfxtechnologies.com](mailto:salesasia@surfxtechnologies.com)